

Krankl Features

- ARM M0 32-Bit MCU
- 433MHz Transceiver
- 160kB Flash / 8kB SRAM
- (2) 8-10 bit ADC
- (26) GPIO control pins
- (9) High Voltage GPIOs
- (2) High Current GPIOs
- Internal 12MHz RC Oscillator
- 10kHz Auxiliary Clock (<1uA)
- 30MHz XTAL Osc
- (1) SPI
- (1) UART
- (3) 12-Bit PWM
- 12V Operation
- POR/BOR

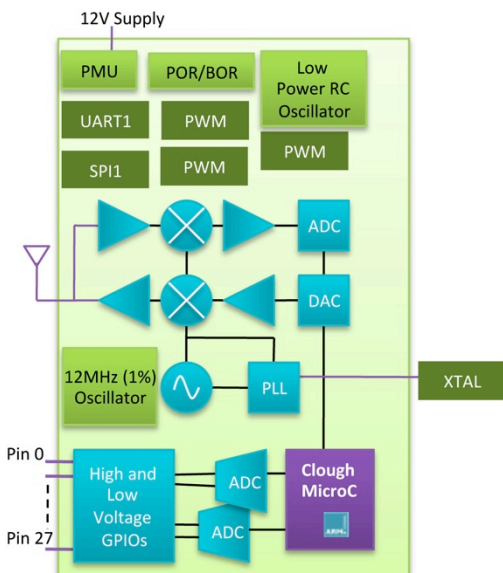

Recommended Applications

- Ceiling Fans
- Garage Door Openers
- Mobile, Industrial, Commercial, Automotive, Medical

iND83231 “Krankl”

High Voltage Wireless – Microcontroller with 32-Bit ARM M0 and 433MHz ISM Band Radio

Device Description

The iND83231 high voltage wireless microcontroller consists of a highly integrated 32-bit general purpose ARM M0 based microcontroller and 433 MHz ISM Band Transceiver and operates from a 12V DC supply.

The integrated wireless transceiver operates in the 433 MHz ISM band with capability from 310MHz – 450 MHz. It has a maximum transmit power of +13dBm and a receive sensitivity in excess of -110dBm. The power consumption of the transceiver leads the industry with 4mA of current consumption in receive mode and 18mA at maximum output power.

The iND83231 also integrates 160kB of flash RAM and 8kB of SRAM on die for feature-rich applications or applications requiring redundancy of data storage. It integrates multiple clocking options including a high accuracy (1%) 12MHz RC oscillator, low power (<1uA) 10kHz auxiliary clock, 30MHz crystal oscillator, and watchdog timer for high performance, low power designs.

The device peripherals include a total of 26 general purpose I/O ports available to the user. Nine of these I/O ports operate at 12V, of which two can drive high currents of 200mA. The device also integrates two 8-10 bit ADCs (SAR architecture).

In addition, the iND83231 offers a UART interface option through the use of GPIO pins and also has three PWM output (12 bits wide) and an SPI interface.

The iND83231 integrates a power management block including on-chip regulators. The device operates from a DC supply with a range from 12-36V and is suitable for industrial and consumer goods such as garage door openers and ceiling fans. The device is packaged in a low cost 6x6mm QFN package.

Ordering Information

Device Ordering Name	Platform	Temp Range	Package	Pins
iND83231 Krankl	General purpose wireless uC applications	-40C to +85C	6x6 mm QFN	40 Pins @ 0.50 mm Pitch